

الامراني العالمية
Alhamrani Universal



Alhamrani Universal

POS Operation Manual

Table of Content

Terminal Overview	1
Ready Display	1
Keys Functions	2
Switching On/OFF	3
Merchant Guide	4
Purchase	4
Purchase with Naqd	6
Reversal	8
Authorization	9
Authorization extension	11
Authorization Void	13
Purchase Advice	15
Cash Advance	17
Transaction Details	19
Supervisor Manual	20
Refund	20
Reconciliation	22
Snapshot balances	23
Running totals	23
Password change	24
DESAF	24
Reprint Last transaction	25
Reprint by invoice	25
Print transaction report	26
Reprint last reconciliation	26
Reprint reconciliation by invoice	27
Reconciliation list	27
Review	28
Display Timeout	29

General Info	30
Error Messages	30
Paper roll change	31



Ready Display is the main display of the POS terminal where you will be able to navigate and access other menus

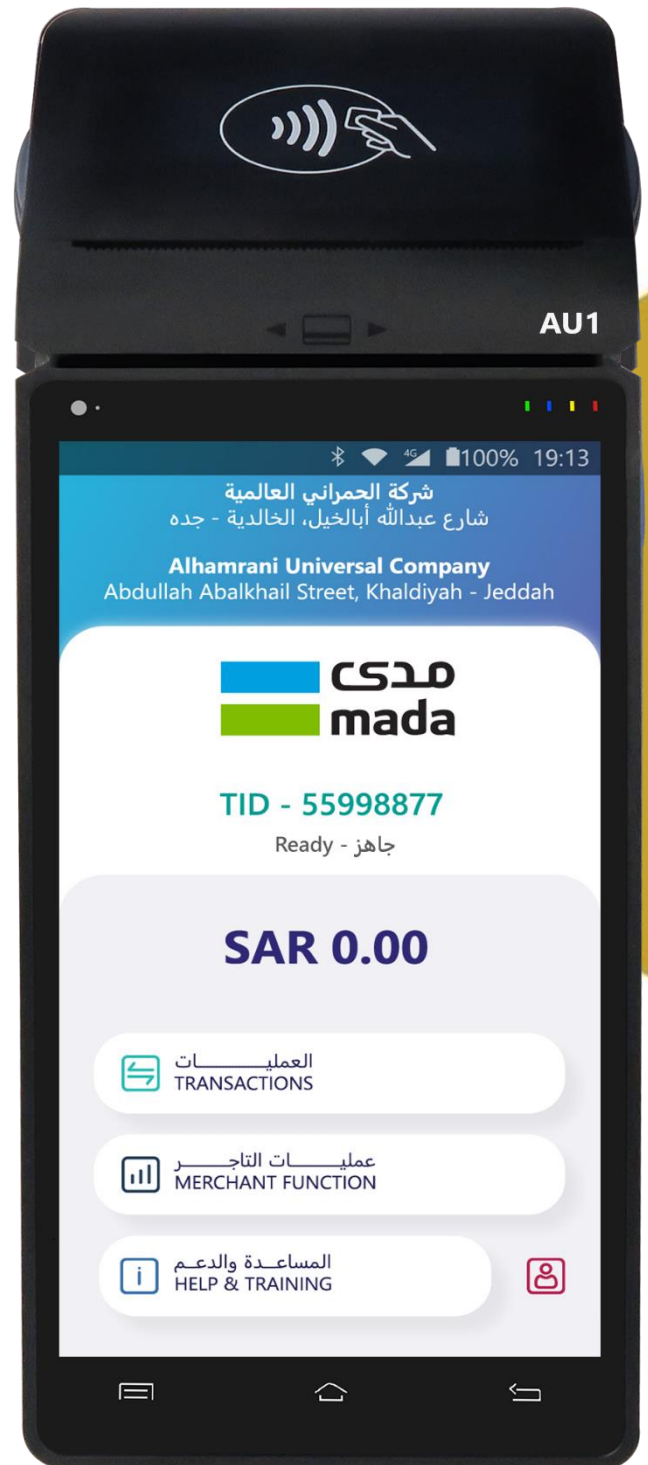



Key Function and Terminal Overview

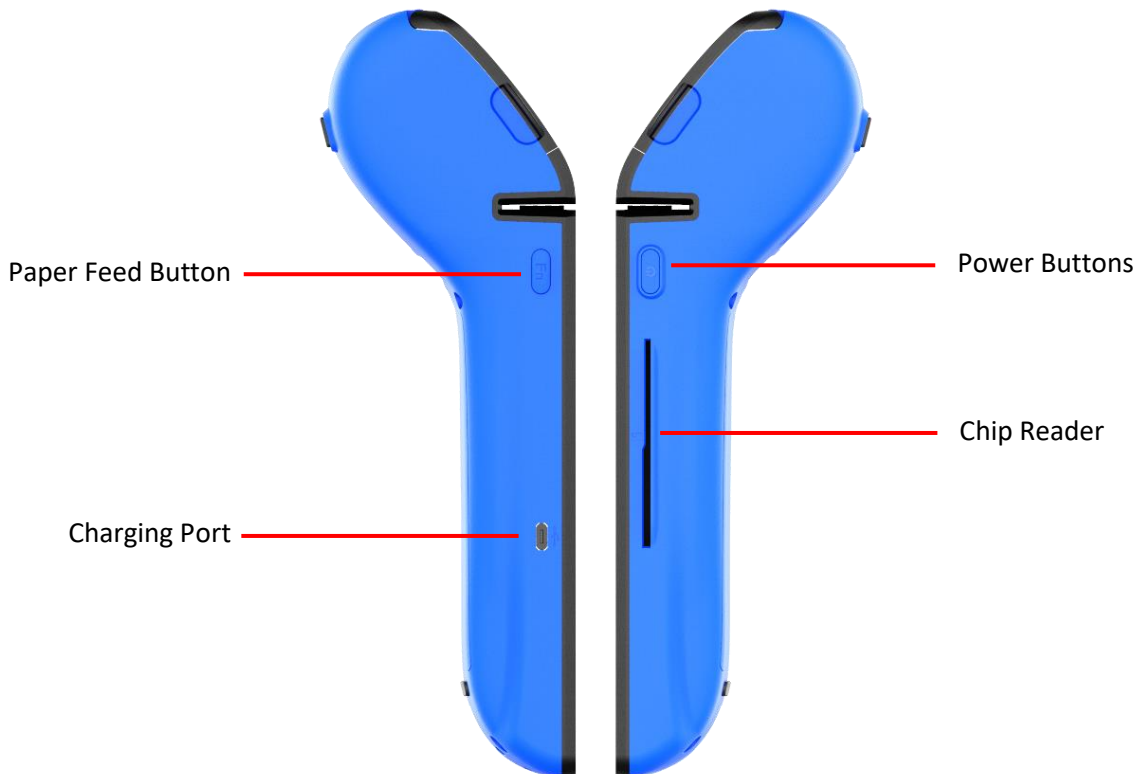



Switching ON / OFF

To switch on the device Press on power button for 6 Seconds and terminal will switch on;

To switch OFF press on power button for two seconds, Select Power off,

Or select restart to restart the device.

To Run mada application press on mada icon below, and wait for the status to appear as "READY"





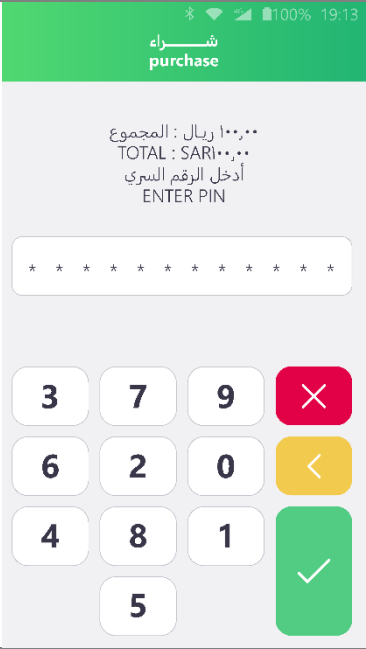

Merchant Guide

Purchase		
A data Capture transaction that debits a cardholder's account in exchange for goods or services		
step	Action	Display
1	On «Ready» display press on 0.00 SAR to initiate a transaction	SAR 0.00
2	Enter Purchase Amount then press on Enter button	<p>SAR 100.00 ريال 1 2 3 إلغاء CANCEL 4 5 6 مسح CLEAR 7 8 9 000 00 0 إدخال ENTER</p>
3	Ather logo will appear on the screen	<p>شراء purchase استخدم البطاقة أو الجهاز PRESENT CARD OR DEVICE SAR 100.00 ١٠٠,٠٠ ريال أدخل تفاصيل البطاقة ENTER CARD DETAILS إلغاء CANCEL</p>
4	Insert/Swipe/Wave your card	
5	Or select "ENTER CARD DETAILS" for manual entry transactions	أدخل تفاصيل البطاقة ENTER CARD DETAILS
6	Key-in Expiry date and Card number Then press on CONTINUE	<p>تفاصيل البطاقة CARD DETAILS تاريخ الانتهاء سنة / شهر EXPRY DATE MM / YY رقم البطاقة CARD NUMBER إلغاء cancel الاستمرار CONTINUE</p>







7	Customer should enter his PIN, then press ENTER	
8	Terminal will process the transaction and print the receipt	



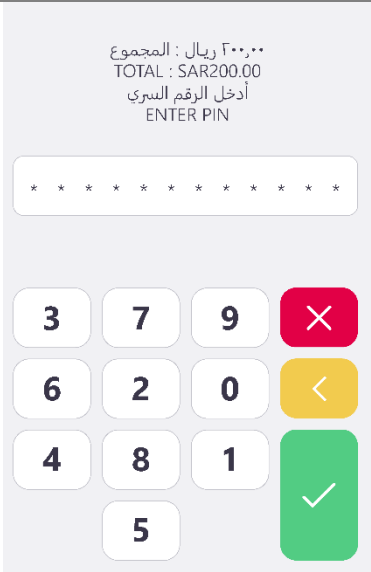





Purchase with Naqd		
A Purchase transaction where the amount of the transaction represents both the value of the goods or services and of a cash amount requested by the cardholder.		
step	Action	Display
1	On «Ready» display press on TRANSACTIONS	 العمليات TRANSACTIONS
2	Select PUR WITH NAQD	 شراء مع نقد PUR WITH NAQD
3	Key-in Purchase Amount then press ENTER	
4	Key-in NAQD amount then press ENTER	
5	Atheer logo will appear on the screen	
6	Wave or insert your card	



7	Customer should enter his PIN, then press ENTER	
8	Terminal will process the transaction and print the receipt	

Reversal		
A cancel transaction to reverse the previous purchase within time limit of 60 seconds		
step	Action	Display
1	On «Ready» display press on TRANSACTIONS	 العمليات TRANSACTIONS
2	Select REVERSAL	 عملية معكوسة REVERSAL
3	Key-in merchant password, then select OK	 عملية معكوسة REVERSAL شراء : ريال : ١٠٠.٠٠ فاتورة : ١٠٠٦٣٦٠٠٠٠٠٠٠٠ PURCHASE : 100.00 SAR RRN : 1006360000011 <u>CANCEL إلغاء</u> <u>OK موافق</u>
4	Terminal will process the transaction and print the receipt	









Authorization		
Online check of cardholder's account before a purchase is made. This transaction assumes a pre-authorization purchase completion will follow to finalize the purchase.		
step	Action	Display
1	On «Ready» display press on TRANSACTIONS	 العمليات TRANSACTIONS
2	Select AUTHORIZATION	 تفويض AUTHORIZATION
3	Select AUTHORIZATION	 تفويض AUTHORIZATION
4	Enter Authorization amount then press ENTER	
5	Atheer logo will appear on the screen	
6	Insert/Swipe/Wave your card	
7	Or press on "ENTER CARD DETAILS" for manual Entry	 أدخل تفاصيل البطاقة ENTER CARD DETAILS



8	Key-in expiry date and card number then press on CONTINUE	<p>تفاصيل البطاقة CARD DETAILS</p> <p>تاريخ الانتهاء سنة / شهر EXPIRY DATE MM / YY</p> <p>رقم البطاقة CARD NUMBER</p> <p>الغاء cancel</p> <p>الاستمرار CONTINUE</p>
9	Customer should enter his PIN, then press ENTER	<p>المجموع : ريال ١٠٠.٠٠ TOTAL : SAR1٠٠.٠٠ أدخل الرقم السري ENTER PIN</p> <p>* * * * *</p> <p>3 7 9 ✕</p> <p>6 2 0 <</p> <p>4 8 1 ✓</p> <p>5</p>
10	Terminal will process the transaction and print the receipt	



Authorization extension		
Online request to extend the expiry period for a previously authorized Pre-Authorization transaction.		
step	Action	Display
1	On «Ready» display press on TRANSACTIONS	 العمليات TRANSACTIONS
2	Select AUTHORIZATION	 تفويض AUTHORIZATION
3	Select AUTHORIZATION EXTENSION	 تمديد التفويض AUTHORIZATION EXTENSION
4	Enter ORIGINAL TRANSACTION RRN Enter ORIGINAL TRANSACTION DATE In the format DDMMYYYY Enter AUTH CODE / APPROVAL CODE Then press CONTINUE	<p>تفاصيل العملية الأصلية ORIGINAL TRANSACTION DETAILS</p> <p>أدخل رقم فاتورة العملية الأصلي، RRN ENTER ORIGINAL TRANSACTION RRN</p> <p>أدخل تاريخ العملية الأصلي ENTER ORIGINAL TRANSACTION DATE</p> <p>أدخل رمز الموافقة ENTER APPROVAL CODE</p> <p> إلغاء cancel  الاستمرار CONTINUE</p>
5	Ather logo will appear on the screen	<p>تمديد التفويض AUTHORIZATION EXTENSION</p> <p>استخدم البطاقة أو الجهاز PRESENT CARD OR DEVICE</p> <p></p> <p>SAR 0.00 ريال ٠,٠٠</p> <p>أدخل تفاصيل البطاقة ENTER CARD DETAILS</p> <p> إلغاء CANCEL</p>
6	Insert/Swipe/Wave your card	
7	Or press on "ENTER CARD DETAILS" for manual Entry	أدخل تفاصيل البطاقة ENTER CARD DETAILS



8	Key-in expiry date and card number then press on CONTINUE	<p>تفاصيل البطاقة CARD DETAILS</p> <p>تاريخ الانتهاء سنة / شهر EXPIRY DATE MM / YY</p> <p>رقم البطاقة CARD NUMBER</p> <p>الغاء cancel</p> <p>الاستمرار CONTINUE</p>
9	Customer should Key-in his PIN, then press ENTER	<p>٠٠٠ ريال : المجموع TOTAL : SAR0.00</p> <p>أدخل الرقم السري ENTER PIN</p> <p>* * * * *</p> <p>3 7 9 ✕</p> <p>6 2 0 <</p> <p>4 8 1 ✓</p> <p>5</p>
10	Terminal will process the transaction and print the receipt	









Authorization Void		
Full or partial cancellation of a previous Authorization transaction.		
step	Action	Display
1	On «Ready» display press on TRANSACTIONS	العمليات TRANSACTIONS
2	Select AUTHORIZATION	تفويض AUTHORIZATION
3	Select AUTHORIZATION VOID	إلغاء التفويض AUTHORIZATION VOID
4	<p>Enter ORIGINAL TRANSACTION RRN</p> <p>Enter ORIGINAL TRANSACTION DATE In the format DDMMYYYY</p> <p>Enter AUTH CODE / APPROVAL CODE</p> <p>Then press CONTINUE</p>	<p>تفاصيل العملية الأصلية ORIGINAL TRANSACTION DETAILS</p> <p>أدخل رقم فاتورة العملية الأصلي ENTER ORIGINAL TRANSACTION RRN</p> <p>أدخل تاريخ العملية الأصلي ENTER ORIGINAL TRANSACTION DATE</p> <p>أدخل رمز الموافقة ENTER APPROVAL CODE</p> <p> إلغاء cancel الاستمرار CONTINUE</p>
5	Key-in VOID Amount then Press Enter	<p>SAR 100.00 ريال</p> <p> 1 2 3 إلغاء CANCEL</p> <p>4 5 6 مسح CLEAR</p> <p>7 8 9 إدخال ENTER</p> <p>000 00 0</p>



6	Attheir logo will appear on the screen	
7	Insert/Swipe/Wave your card	
8	Or press on "ENTER CARD DETAILS" for manual Entry	
9	Key-in expiry date and card number then press on CONTINUE	
10	Customer should Key-in his PIN, then press ENTER	
11	Terminal will process the transaction and print the receipt	







Purchase Advice		
Follow-up to an approved authorization transaction. It is initiated after the cardholder received the purchased goods or services. The amount entered in this transaction supersedes that entered in the authorization transaction.		
step	Action	Display
1	On «Ready» display press on TRANSACTIONS	
2	Select PURCHASE ADVICE	
3	Select FINAL/PARTIAL, then press PROCEED	<p>نوع الإشعار ADVICE TYPE</p> <p><input checked="" type="radio"/> نهائي - FINAL</p> <p><input type="radio"/> جزئي - PARTIAL</p> <p> </p>
4	<p>Enter ORIGINAL TRANSACTION RRN</p> <p>Enter ORIGINAL TRANSACTION DATE In the format DDMMYYYY</p> <p>Enter AUTH CODE / APPROVAL CODE</p> <p>Then press CONTINUE</p>	<p>تفاصيل العملية الأصلية ORIGINAL TRANSACTION DETAILS</p> <p>أدخل رقم فاتورة العملية الأصلي RRN ENTER ORIGINAL TRANSACTION RRN</p> <p>أدخل تاريخ العملية الأصلي ENTER ORIGINAL TRANSACTION DATE</p> <p>أدخل رمز الموافقة ENTER APPROVAL CODE</p> <p> </p>
5	Key-in Advice Amount then Press Enter	<p>SAR 100.00 ريال</p> <p></p>



6	Attheir logo will appear on the screen	
7	Insert/Swipe/Wave your card	
8	Or press on "ENTER CARD DETAILS" for manual Entry	
9	Key-in expiry date and card number then press on CONTINUE	
10	Customer should enter his PIN, then press ENTER	
11	Terminal will process the transaction and print the receipt	



Cash advance		
A manual cash disbursement		
step	Action	Display
1	On «Ready» display press on TRANSACTIONS	 العمليات TRANSACTIONS
2	Select CASH ADVANCE	 سلفة نقدية CASH ADVANCE
3	Key-in Cash Amount, then press ENTER	
4	Insert/Swipe the card	

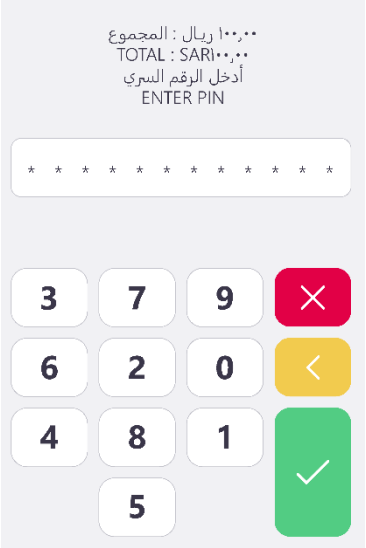

5	Customer should enter his PIN, then press ENTER	
6	Terminal will process the transaction and print the receipt	



Transactions Details:

ستاربكس
STARBUCKS
بلازا ٢، الرياض
The Plaza 2

27/10/2021 00:26:08

SABB 452003080143 5533655745200308
5814 024334 AU.01J

موازنة

RECONCILIATION
المجاميع متوافقة

TOTALS MATCHED

AMERICAN EXPRESS امركان اكسپرس

mada HOST خادم مدى

نوع العملية TXN TYPE	العدد COUNT	مبلغ (ريال) AMOUNT-SAR
إجمالي المدين TOTAL DB	2	35.00
إجمالي الدائن TOTAL CR	0	0.00
نقد NAQD	-	0.00
سلفة نقدية C/ADV	-	0.00
تفويض AUTH	0	-
المجموع TOTALS	-	35.00

جهاز نقطة البيع

POS TERMINAL

نوع العملية	العدد	مبلغ (ريال)

ستاربكس
STARBUCKS
بلازا ٢، الرياض
The Plaza 2

27/10/2021 12:45:56

SABB 452003080143 5533655745200308
5814 024463 AU.01J 271245026507

مدى

mada شراء

PURCHASE
422818*****4460 11/22

مبلغ الشراء
٥٦,٠٠ ريال
PURCHASE AMOUNT
SAR56.00

مقبولة
APPROVED
لا يتطلب التحقق
NO VERIFICATION REQUIRED

رمز الموافقة
001246
APPROVAL CODE

27/10/2021 12:45:59

شكراً لاستخدامكم مدى
THANK YOU FOR USING mada

Trans. Date

RRN

Approval code/
Auth Code





Supervisor Manual

Refund		
A data capture transaction that is initiated by the retailer to credit the cardholder for a refund of goods or services, and to debit the retailer account accordingly.		
step	Action	Display
1	On «Ready» display press on TRANSACTIONS	
2	Select REFUND	
3	Key-in Merchant password then press OK	
4	Enter ORIGINAL TRANSACTION RRN Enter ORIGINAL TRANSACTION DATE In the format DDMMYYYY Then press CONTINUE	
5	Key-in Refund Amount the press ENTER	







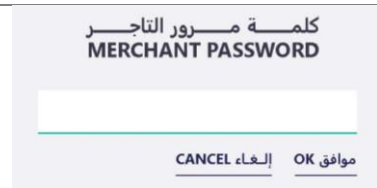

6	Attheir logo will appear on the screen	
7	Insert/Swipe/Wave your card	
8	Or press on "ENTER CARD DETAILS" for manual Entry	
9	Key-in expiry date and card number then press on CONTINUE	
10	Customer should enter his PIN, Then press ENTER	
11	Terminal will process the transaction and print the receipt	







Reconciliation		
The supervisor should select this operation at the end of day, so that the totals will be validated against the bank totals since the last reconciliation operation.		
step	Action	Display
1	On «Ready» display, Select MERCHANT FUNCTION	 عمليات التاجر MERCHANT FUNCTION
2	Key-in Merchant password, then press OK	
3	Select RECONCILIATION	 موازنة RECONCILIATION
4	Key-in Merchant password, then press OK	
5	Terminal will perform a reconciliation and print the receipt	





Snapshot Balances		
The supervisor can perform this operation at any time to print the totals without resetting it.		
step	Action	Display
1	On «Ready» display, Select MERCHANT FUNCTION	 عمليات التاجر MERCHANT FUNCTION
2	Key-in Merchant password, then press OK	 كلمة مرور التاجر MERCHANT PASSWORD CANCEL إلغاء OK موافق
3	Select SNAPSHOT BALANCES	 حسبة لحظية SNAPSHOT BALANCES
4	Terminal will print the balances	



Running Totals		
The supervisor could perform this operation at the end of each shift to print the totals without without resetting it, the terminal will start to count totals for the next shift.		
step	Action	Display
1	On «Ready» display, Select MERCHANT FUNCTION	 عمليات التاجر MERCHANT FUNCTION
2	Key-in Merchant password, then press OK	 كلمة مرور التاجر MERCHANT PASSWORD CANCEL إلغاء OK موافق
3	Select RUNNING TOTALS	 مجاميع جارية RUNNING TOTALS
4	Terminal will print the receipt	









Password Change		
Used to change Merchant password		
step	Action	Display
1	On «Ready» display, Select MERCHANT FUNCTION	 عمليات التاجر MERCHANT FUNCTION
2	Key-in Merchant password, then press OK	 كلمة مرور التاجر MERCHANT PASSWORD [Input field] إلغاء CANCEL موافق OK
3	Select Password Change	 تغيير كلمة المرور PASSWORD CHANGE
4	Enter old Password Enter the new password Re-Enter the new password Then Press on OK	 كلمة مرور التاجر MERCHANT PASSWORD كلمة المرور القديمة OLD PASSWORD [Input field] كلمة المرور الجديدة NEW PASSWORD [Input field] ادخل كلمة المرور مرة أخرى RETYPE NEW PASSWORD [Input field] إلغاء CANCEL موافق OK



DESAF		
DESAF is used to send the stored advices; usually this task is being done automatically.		
step	Action	Display
1	On «Ready» display, Select MERCHANT FUNCTION	 عمليات التاجر MERCHANT FUNCTION
2	Key-in Merchant password, then press OK	 كلمة مرور التاجر MERCHANT PASSWORD [Input field] إلغاء CANCEL موافق OK
3	Select DESAF	 ارسال إشعار العمليات DESAF
4	Terminal will send the stored advices	



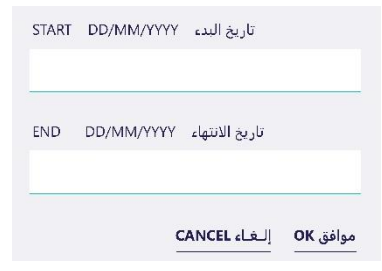

Print last transaction		
Used to print the last transaction performed		
step	Action	Display
1	On «Ready» display, Select MERCHANT FUNCTION	 عمليات التاجر MERCHANT FUNCTION
2	Key-in Merchant password, then press OK	 كلمة مرور التاجر MERCHANT PASSWORD CANCEL إلغاء OK موافق
3	Select LAST TRANSACTION	 آخر عملية LAST TRANSACTION
4	Terminal will reprint the receipt	





Re-print transaction using invoice number		
Used to reprint transactions receipts using Invoice number "last 6 digits of RRN"		
step	Action	Display
1	On «Ready» display, Select MERCHANT FUNCTION	 عمليات التاجر MERCHANT FUNCTION
2	Key-in Merchant password, then press OK	 كلمة مرور التاجر MERCHANT PASSWORD CANCEL إلغاء OK موافق
3	Select REPRINT BY INVOICE	 إعادة الطباعة برقم الفاتورة REPRINT BY INVOICE
4	Key-in Invoice number then press OK	 أدخل رقم الإيصال ENTER INVOICE NUMBER CANCEL إلغاء OK موافق
5	Terminal will reprint the receipt	

Print transaction report		
Used to print approved transaction report for one day or more		
step	Action	Display
1	On «Ready» display, Select MERCHANT FUNCTION	 عمليات التاجر MERCHANT FUNCTION
2	Key-in Merchant password, then press OK	 كلمة مرور التاجر MERCHANT PASSWORD [Input field] CANCEL إلغاء OK موافق
3	Select REPRINT BY DATE	 إعادة الطباعة بالتاريخ REPRINT BY DATE
4	Enter Start Date DD/MM/YYYY Then press OK for a single day, Or Enter Start Date DD/MM/YYYY Then enter End date DD/MM/YYYY Then Press OK for a range of time	 START DD/MM/YYYY تاريخ البدء [Input field] END DD/MM/YYYY تاريخ الانتهاء [Input field] CANCEL إلغاء OK موافق
5	Terminal will print the report	

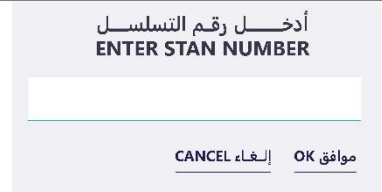



Reprint last reconciliation		
Used to Reprint the receipt of the last reconciliation performed		
step	Action	Display
1	On «Ready» display, Select MERCHANT FUNCTION	 عمليات التاجر MERCHANT FUNCTION
2	Key-in Merchant password, then press OK	 كلمة مرور التاجر MERCHANT PASSWORD [Input field] CANCEL إلغاء OK موافق
3	Select LAST RECON	 آخر موازنة LAST RECON
4	Terminal will Reprint the receipt	







Reprint recon by invoice		
Used to reprint a reconciliation using STAN number		
step	Action	Display
1	On «Ready» display, Select MERCHANT FUNCTION	 عمليات التاجر MERCHANT FUNCTION
2	Key-in Merchant password, then press OK	 كلمة مرور التاجر MERCHANT PASSWORD [Input field] CANCEL إلغاء OK موافق
3	Select RECON BY INVOICE	 إيصال الموازنة RECON BY INVOICE
4	Enter STAN number then press OK	 أدخل رقم التسلسل ENTER STAN NUMBER [Input field] CANCEL إلغاء OK موافق
5	Terminal will reprint the receipt	

Reconciliation list		
Used to display and print reconciliations list		
step	Action	Display
1	On «Ready» display, Select MERCHANT FUNCTION	 عمليات التاجر MERCHANT FUNCTION
2	Key-in Merchant password, then press OK	 كلمة مرور التاجر MERCHANT PASSWORD [Input field] CANCEL إلغاء OK موافق
3	Select RECON LIST	 قائمة الموازات RECON LIST
4	Terminal will display Reconciliation details Select PRINT to print the report	 قائمة الموازات RECON BY LIST DTTM STAN ACTION_CODE FUNC_CODE NO_TXN (**) 2021-10-12 10:09:30 000099 500 M 2021-10-12 10:09:30 000120 500 M 2021-10-12 10:09:30 000301 500 M 2021-10-12 10:09:30 000441 500 M طباعة PRINT إلغاء CANCEL



Review		
Used to display transactions details before being settled		
step	Action	Display
1	On «Ready» display, Select MERCHANT FUNCTION	 عمليات التاجر MERCHANT FUNCTION
2	Key-in Merchant password, then press OK	 كلمة مرور التاجر MERCHANT PASSWORD [Input field] CANCEL إلغاء OK موافق
3	Select REVIEW	 معاينة REVIEW
4	Terminal will display Transactions details, Use the buttons (NEXT, BACK) to navigate through the txns, Use the button Print to print the receipt. Or press Cancel to go back	 معاينة REVIEW BATCH NUMBER / رقم الدفعة 0005 RNN / رقم الفاتورة 012060089133 TRANSACTION / العملية شراء - PURCHASE AMOUNT / المبلغ 130.00 CARD SCHEME / شبكة الدفع مدى - mada CARD NUMBER / رقم البطاقة 508848*****1234 RESPONSE / استجابة مقبولة - approved DATE / تاريخ 12/12/2012 STATUS / الحالة - pending recon [BACK] [cancel] [PRINT] [NEXT]



Display Timeout		
Used to change Display time out duration.		
step	Action	Display
1	On «Ready» display, Select MERCHANT FUNCTION	 عمليات التاجر MERCHANT FUNCTION
2	Key-in Merchant password, then press OK	 كلمة مرور التاجر MERCHANT PASSWORD CANCEL إلغاء OK موافق
3	Select Display Timeout	 مهلة العرض DISPLAY TIMEOUT
4	Key-in the required Value in minutes then press OK	 DIPLAY TIMEOUT مهلة العرض 00, 30, 10, 5, 2, 1 دقيقة 1, 2, 5, 10, 30, 00 MINUTES CANCEL إلغاء OK موافق
5	Terminal will adjust the timeout duration to the selected Value	



GENERAL INFO

ERROR MESSAGES

Error Message	Description
PAPER OUT	Displayed when paper failure has been detected by the terminal
CARD ERROR	The card is swiped incorrectly or the card reader is defective
CARD FAIL	Displayed when no data detected on the chip card
MANUAL ENTRY NOT ALLOWED	Manually entered card numbers are not allowed in this operation
RETRY PIN / INCORRECT PIN / WRONG PIN	Displayed when an incorrect PIN has been entered
EXPIRED CARD	The card is already expired, or the expiry date is incorrectly entered
CARD BLOCKED	Displayed when the card is blocked
PIN BLOCKED	Displayed when the offline PIN has been blocked
TRIES LEFT : XX	Displayed when an offline PIN has been incorrectly entered. XX is the number of tries remaining
PIN RETRIES EXCEEDED	Displayed when PIN attempts has reached the maximum number of tries
AMOUNT / TRANS EXCEEDED	Displayed when the merchant attempted a transaction where the amount exceeded the amount limit for card scheme
USER CANCELLED	Transaction cancelled by merchant
CARD DECLINED	Transaction declined by card
PLEASE RECONCILE / TERMINAL OUT OF SERVICE	Displayed when the terminal requires reconciliation
RECONCILIATION UNSUCCESSFUL	Indicates that reconciliation was completed. However, the terminal and host totals are unbalanced



CHANGE PAPER ROLL

description

Hold the terminal securely in one hand. With the other hand and by using Two fingers, lift the printer cover release from the edges at both sides

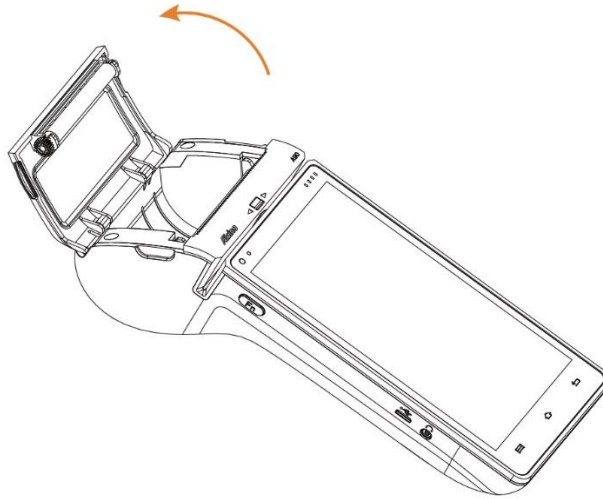

Fully open the printer cover and remove the old roll of paper; Carefully place the paper roll into the printer compartment. Close the printer cover carefully and push firmly until it locks.

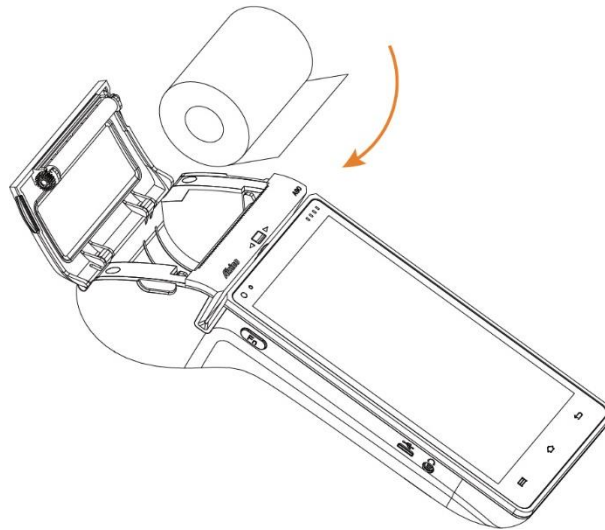

NOTE: Attempting to fit rolls of a different size may damage your terminal.